

μGrind HPS 20 und HPS 20L



good better BLUE

GDS[®]
Made in Germany

The μ Grind HPS 20 **automatic chuck** can be setup to virtually eliminate runout in just a few minutes, using two simple gauges.



We developed the μ Grind in close cooperation with leading tool grinding professionals specifically to achieve high precision clamping in that field.

The chuck uses specialized shallow taper (1°) collets for outstanding clamping force. Plus the collets can be changed in seconds without any tools or readjustment, enabling quick diameter changes.

The chuck is “self-clamping,” (it clamps the tool without external force and releases upon activation of a pneumatic push rod). A spring-like mechanism applies a constant pull on the collet to clamp the tool. Because that linkage is not rigid, the collet (and therefore the tool blank) cannot be pulled crooked.

Setup requires just a few minutes and neither special skills nor tools. Even weeble-wobble can be virtually eliminated just by adjusting screws.

Adjust **concentricity** // Eliminate **runout**

The μ Grind gives you the ability to quickly and easily adjust axial runout and “weeble-wobble” yielding a **new dimension in grinding precision**.

Setup - **Concentric with the machine**

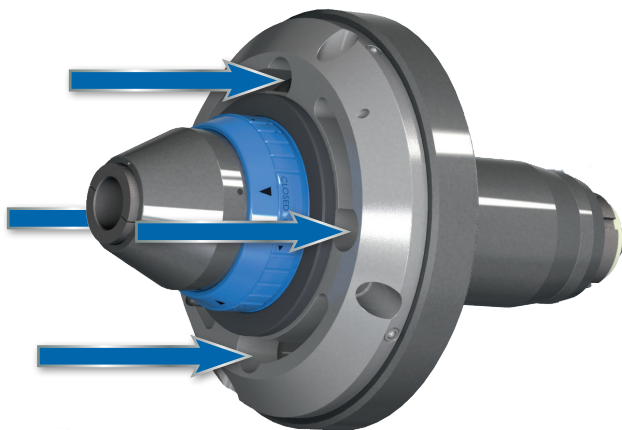

Setup - **Parallel with the machine**

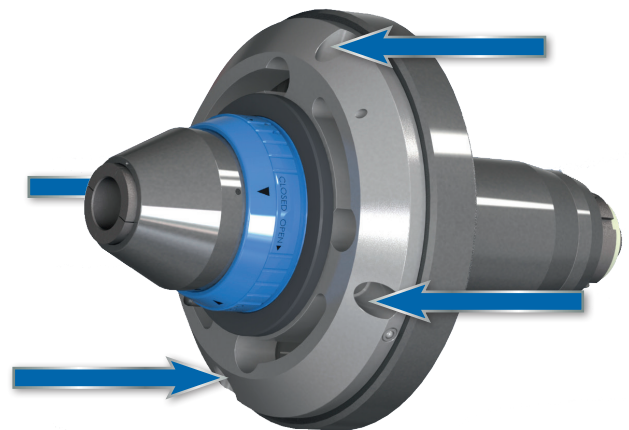

μ Grind HPS20 / HPS20L

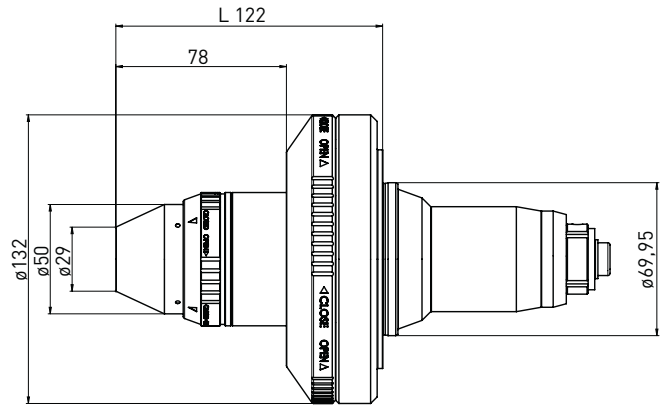
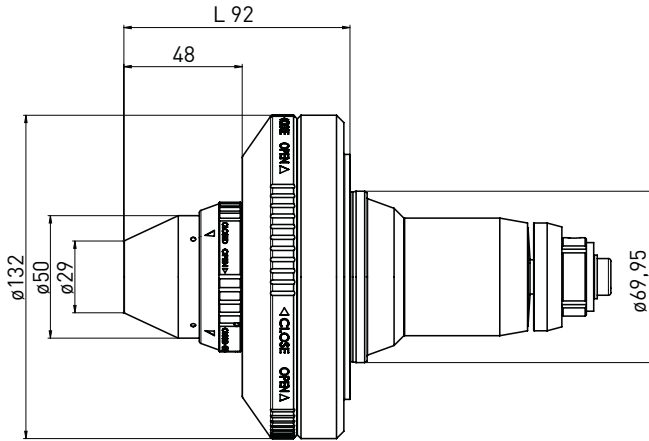

Delivery includes:

Case, actuating pushrod, plastic tipped hammer, wrench, USB stick with instructions

Item No.	Name	D(mm)	L
400001000	μ Grind HPS 20	69,95	92
400001001	μ Grind HPS 20L	69,95	122

Available for the following machines:



- Helitronic Mini Power (excluding Mini Automation)
- Helitronic Power
- Helitronic Vision
- Helitronic Essential
- Measuring machine: Helicheck



Lets you adjust both runout and weeble-wobble to within two microns at 2½ x D without special tools or skill

Handles shanks from 3 to 20 mm (1/8 to 3/4 inches)

Lets you change diameters in seconds and maintains its precision without adjustment

Performs like this over tens of thousands of clampings

Requires a relatively short clamping length on the blank to achieve constant holding force and concentricity

Features a tapered profile and smaller nose diameter than hydraulic holders for better wheel clearance and freedom from interference

Offers excellent dampening properties for uniform material removal, optimized feed rates, excellent surface finish, and significantly reduced grinding wheel wear

Suitable for both high production and regrounding

Accessories flat clamping sleeves:

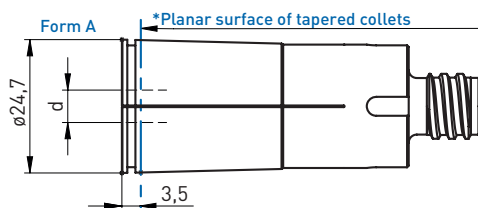

Item No.	Name - \varnothing d	Form
350260003	HPS Clamping sleeve 20 - \varnothing 3 mm	A
350260004	HPS Clamping sleeve 20 - \varnothing 4 mm	A
350260005	HPS Clamping sleeve 20 - \varnothing 5 mm	A
350260006	HPS Clamping sleeve 20 - \varnothing 6 mm	A
350260007	HPS Clamping sleeve 20 - \varnothing 7 mm	A
350260008	HPS Clamping sleeve 20 - \varnothing 8 mm	A
350260009	HPS Clamping sleeve 20 - \varnothing 9 mm	A
350260010	HPS Clamping sleeve 20 - \varnothing 10 mm	A
350260011	HPS Clamping sleeve 20 - \varnothing 11 mm	A
350260012	HPS Clamping sleeve 20 - \varnothing 12 mm	A
350260013	HPS Clamping sleeve 20 - \varnothing 13 mm	A
350260014	HPS Clamping sleeve 20 - \varnothing 14 mm	A
350260015	HPS Clamping sleeve 20 - \varnothing 15 mm	A
350260016	HPS Clamping sleeve 20 - \varnothing 16 mm	A
350260017	HPS Clamping sleeve 20 - \varnothing 17 mm	A
350260018	HPS Clamping sleeve 20 - \varnothing 18 mm	A
350260019	HPS Clamping sleeve 20 - \varnothing 19 mm	A
350260020	HPS Clamping sleeve 20 - \varnothing 20 mm	A
350260201	HPS Clamping sleeve 20 - \varnothing 1/8"	A
350260202	HPS Clamping sleeve 20 - \varnothing 3/16"	A
350260203	HPS Clamping sleeve 20 - \varnothing 1/4"	A
350260204	HPS Clamping sleeve 20 - \varnothing 5/16"	A
350260205	HPS Clamping sleeve 20 - \varnothing 3/8"	A
350260206	HPS Clamping sleeve 20 - \varnothing 7/16"	A
350260207	HPS Clamping sleeve 20 - \varnothing 1/2"	A
350260208	HPS Clamping sleeve 20 - \varnothing 9/16"	A
350260209	HPS Clamping sleeve 20 - \varnothing 5/8"	A
350260210	HPS Clamping sleeve 20 - \varnothing 11/16"	A
350260211	HPS Clamping sleeve 20 - \varnothing 3/4"	A

Accessories tapered clamping sleeves:

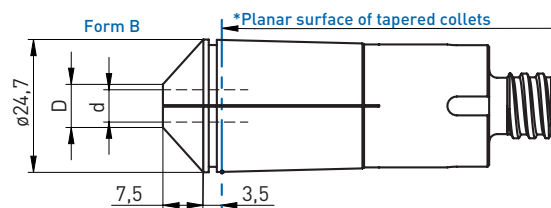

Item No.	Name - \varnothing d	Form
350260130	HPS Clamping sleeve 20K - \varnothing 2,35 mm	B
350260103	HPS Clamping sleeve 20K - \varnothing 3 mm	B
350260104	HPS Clamping sleeve 20K - \varnothing 4 mm	B
350260105	HPS Clamping sleeve 20K - \varnothing 5 mm	B
350260106	HPS Clamping sleeve 20K - \varnothing 6 mm	B
350260301	HPS Clamping sleeve 20K - \varnothing 1/8"	B
350260302	HPS Clamping sleeve 20K - \varnothing 3/16"	B
350260303	HPS Clamping sleeve 20K - \varnothing 1/4"	B

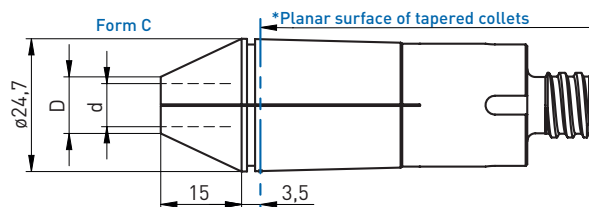

Item No.	Name - \varnothing d	Form
350260107	HPS Clamping sleeve 20K - \varnothing 7 mm	C
350260108	HPS Clamping sleeve 20K - \varnothing 8 mm	C
350260109	HPS Clamping sleeve 20K - \varnothing 9 mm	C
350260110	HPS Clamping sleeve 20K - \varnothing 10 mm	C
350260111	HPS Clamping sleeve 20K - \varnothing 11 mm	C
350260112	HPS Clamping sleeve 20K - \varnothing 12 mm	C
350260304	HPS Clamping sleeve 20K - \varnothing 5/16"	C
350260305	HPS Clamping sleeve 20K - \varnothing 3/8"	C
350260306	HPS Clamping sleeve 20K - \varnothing 7/16"	C
350260307	HPS Clamping sleeve 20K - \varnothing 1/2"	C



Minimum clamping depth of 2,5 x \varnothing from *clamping chuck's plane surface.



GDS local distributors in Europe

Our qualified partners **take care of you**, where we can't be in person, providing optimal support and answers to your questions.

AUSTRIA

plan:b4u GmbH

Colmarplatz 1 / Top XXIII
7000 Eisenstadt Austria
Tel: +43 664 127 3039
Email: info@planb4u.com
Web: www.planb4u.com

CZECH/SLOVAKIA

Dr. MÜLLER DIAMANTMETALL AG

Leprosenweg 34
82362 Weilheim i. Ob. Germany
Tel: +49 (0) 881 - 90 11 55-0
Fax: +49 (0) 881 - 90 11 55-100
Email: vertrieb@muedia.de
Web: www.muedia.de

FINLAND

Diamack Oy

Asentajankatu 9 C
48770 Kotka Finland
Tel: +358 5 - 21 41 20
Fax: +358 5 - 21 41 70
Email: diamack@diamack.fi
Web: www.diamack.fi

FRANCE

oelheld technologies SAS

innovative fluid technology
Technopôle de Forbach-Sud
140, Avenue Jean-Eric Bousch
57600 Oeting France
Tel: +33 (0) 387-90 42 14
Fax: +33 (0) 387-84 66 91
Email: martin.gundelach@oelheld.de
Web: www.oelheld.com

HUNGARY

Szerszám Technika Kft.

Dűlő u. 4.
1225 Budapest Hungary
Tel: +36 1 287 82 76
Fax: +36 1 287 82 77
Email: info@szerszamtechnika.hu
Web: www.szerszamtechnika.hu

ITALY

Utensileria FAVRIN Srl

Via Per Cabiate 79
22066 Mariano Comense Italy
Tel: +39 (0) 31 - 74 72 00
Fax: +39 (0) 31 - 75 12 22
Email: utensileria-mariano@favrin.it
Web: www.utensileria-favrin.it

NETHERLANDS

GDS Präzisionszspanungs GmbH

Endelbergstrasse 8
72131 Ofterdingen Germany
Tel: +49 (0) 74 73 - 27 26 72
Fax: +49 (0) 74 73 - 27 26 49
Email: sales@gds-praezision.de
Web: www.gds-praezision.de

POLAND

Vollmer Polska sp z o.o.

ul.Handlowa 11
41-807 Zabrze Poland
Tel: +48 32 733 08 69
Email: info-pl@vollmer-group.com
Web: www.vollmer-group.com

PORTUGAL // SPAIN

Procut

Parque Industrial Cruzeiro
Rua Nossa Senhora da Ajuda 150
4815-364 Moreira de Conegos Portugal
Tel: +351 253 56 12 11
Fax: +351 253 56 39 49
Email: info@procut.pt
Web: www.procut.pt

SWEDEN

Ehn & Land AB

Bultvägen 4
553 02 Jönköping Sweden
Tel: +46 86 35 34-50
Fax: +46 86 35 34-70
Email: info@ehmland.se
Web: www.ehmland.se

SWITZERLAND

Ziegler + Cie AG

Industriestraße 12
8404 Winterthur Switzerland
Tel: +41 (0) 52 234 20 20
Fax: +41 (0) 52 234 20 10
Email: info@zieglerag.ch
Web: www.zieglerag.ch

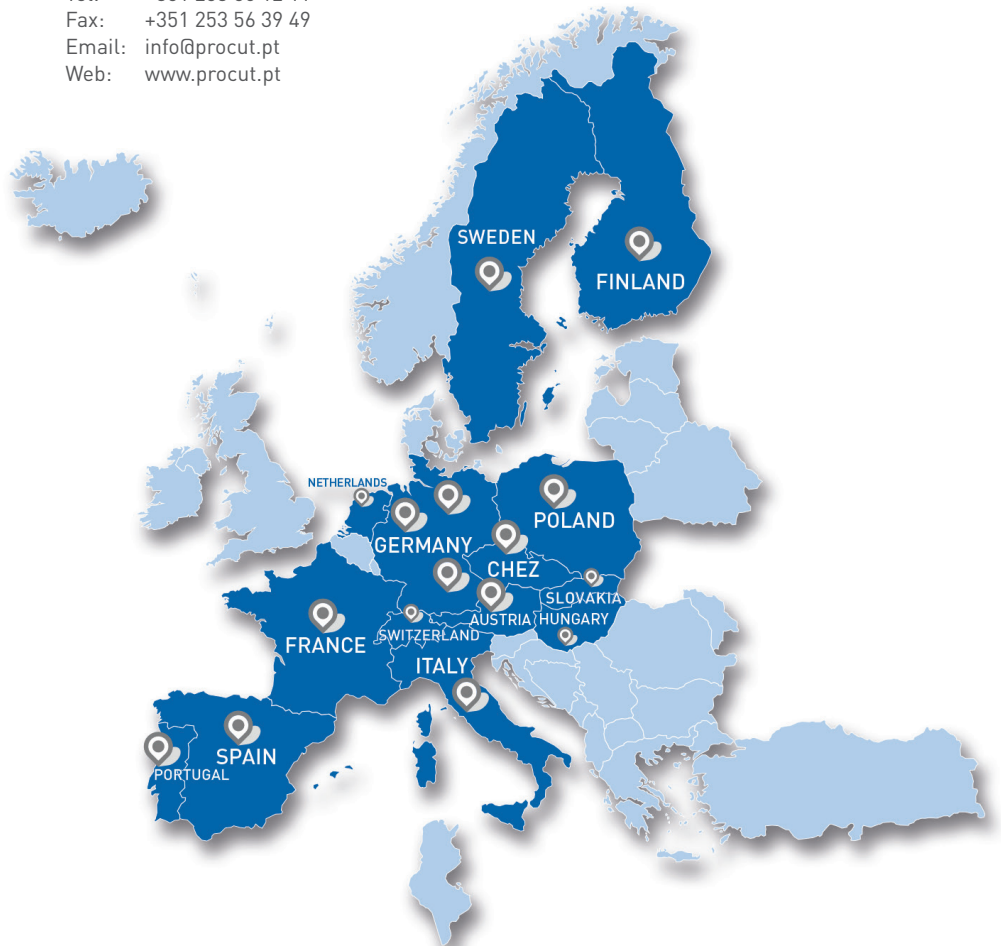

GDS local sales and service partners **Worldwide**

AUSTRALIA

Camco Cutting Tools Int'l Pty. Ltd.

1/25 Mareno Rd., P.O. Box 1575,
Tullamarine, Victoria, 3043 **Australia**

Tel: +61 (0)3 8336 1500

Fax: +61 (0)3 8336 1499

Mob: +61 (0)413 126 868

Email: sales@camcointl.com

BRAZIL

Metalsystem

Rua João Pereira Chaves, 440
RS 93032-320 Jardim America, São Leopoldo **Brazil**

Tel: +55 51 8159-8455

Email: vendas@metalsystem.ind.br

Email: renato@metalsystem.ind.br

Web: www.metalsystem.ind.br

CHINA

HERZOG CHINA CO.,LTD.

4/F, No.3232 Beimen Road,
Kunshan, Jiangsu 215316, **China**

Tel: +86-512-55 19 05 78

Fax: +86-512-55 19 05 76

Email: dezhu@herzog-china.com

Web: www.herzog-china.com

Changzhou Technology Service Center

West Street 255#, Xixiashu Town,
Xinbei District, Changzhou City,
Jiangsu Province, **China**

Tel: +86-519-83 85 09 55

Email: dezhu@herzog-china.com

South China Technology Service Center

FuYuan Business Center 206#, 1# 13th Alley,
MaiYuan Road, XinAn Community, ChangAn Town,
DongGuan City, GuangDong Province, **China**

Tel: +86-769-81 88 99 62

Email: dezhu@herzog-china.com

INDIA

TMS PRECISION TECH PVT. LTD

B2-302, Regency Cosmos
Baner Road, Pune: 411045 **India**

Tel: +91 904 999 0855

Email: mayur.shinde@tmsprecisiontech.com

Web: www.tmsprecisiontech.com

ISRAEL

De-Paz Machinery - CNC machines & Accessories

Menachem Begin 80 Blvd
Afula. 1871356 **Israel**

Tel: +972-54-421 48 72

Email: zion@de-paz.com

Web: www.de-paz.com

JAPAN

NK Works Co., Ltd.

Nagoya Branch
1-336 Namiki Nakamura-ku
Nagoya Aichi 453-0856 **Japan**

Tel: +81 52 - 4 19 - 25 01

Email: y_kawamura@nk-works.co.jp

KAZAKHSTAN

Handelsagentur Germany

Brak Vladimir
Martin-Seitz-Straße 6a
94036 Passau **Germany**

Tel: +49 (0) 851 - 4 90 29 61

Fax: +49 (0) 851 - 4 90 29 61

Email: info-gerus@gmx.de

RUSSIA

AWM Precision GmbH

Genshagener Straße 27
14974 Ludwigsfelde **Germany**

Tel: +49 (0) 33 78 - 5 18 63 67

Email: arnold@awm-precision.de

Web: www.awm-precision.com

KOREA

Central Technology Co. Ltd

D-1311, Gwangmyeong Techno Park, Haanro 60,
Gwangmyeong-Si, Gyeonggi-Do, 423-050 **Korea**

Tel: +82-2-897-0945

Fax: +82-2-897-0943

Email: ycr@centraltech.co.kr

Web: www.centraltech.co.kr

PACIFIC (Indonesia, Malaysia, Singapore, Thailand)

ALLIED CHANCE (S) PTE LTD

BLK. 1 Wholesale Ctr. #02-08
Pasir Panjang Wholesale CTR.
Singapore 110001

Tel: +65-67 78 02 63

Fax: +65-67 78 79 62

Email: paul.lai@allied-chance.com

TAIWAN

HERZOG Taiwan Co., Ltd.

10F, No.70 Gongyequ 1st Rd., Situn Dist.
Taichung City 40766, **Taiwan (R.O.C.)**

Tel: +886-4-23 55-33 88

Fax: +886-4-23 55-22 99

Email: afly@costa.com.tw

Web: www.costa.com.tw

TURKEY

Mikron Otomasyon ve CNC Teknolojileri

Yalı yolu sok.
Panorama Life 4-6A No:1
34882 Kartal **Istanbul**

Tel: +90 216 671 03 24

Email: info@mikronotomasyon.com

USA // CANADA

Toolroom Solutions Inc.

Ed Sinkora
8824 Old Block House Ln
22551 Spotsylvania **USA**

Tel: +1 540 9 40 - 59 77

Email: ed@toolroom.solutions

VIETNAM

Central Technology Co. Ltd

D-1311, Gwangmyeong Techno Park, Haanro 60,
Gwangmyeong-Si, Gyeonggi-Do, 423-050 **Korea**

Tel: +82-2-897-0945

Fax: +82-2-897-0943

Email: ycr@centraltech.co.kr

Web: www.centraltech.co.kr

